



GLOBAL STANDARD  
VERTICAL MACHINING CENTER

# DNM

4500/L • 5700/L • 6700/L/XL



# DNM SERIES

**4500/L • 5700/L • 6700/L/XL**

Building on the legacy of the proven and successful DNM and DNM II series, the new version DNM series boasts even greater reliability and improved performance. In addition, the new series includes grease lubrication to the roller guideways which is more environmentally-friendly. The design concepts underpinning the DNM 4500/5700/6700 series are high speed, high rigidity and suitability for all applications.

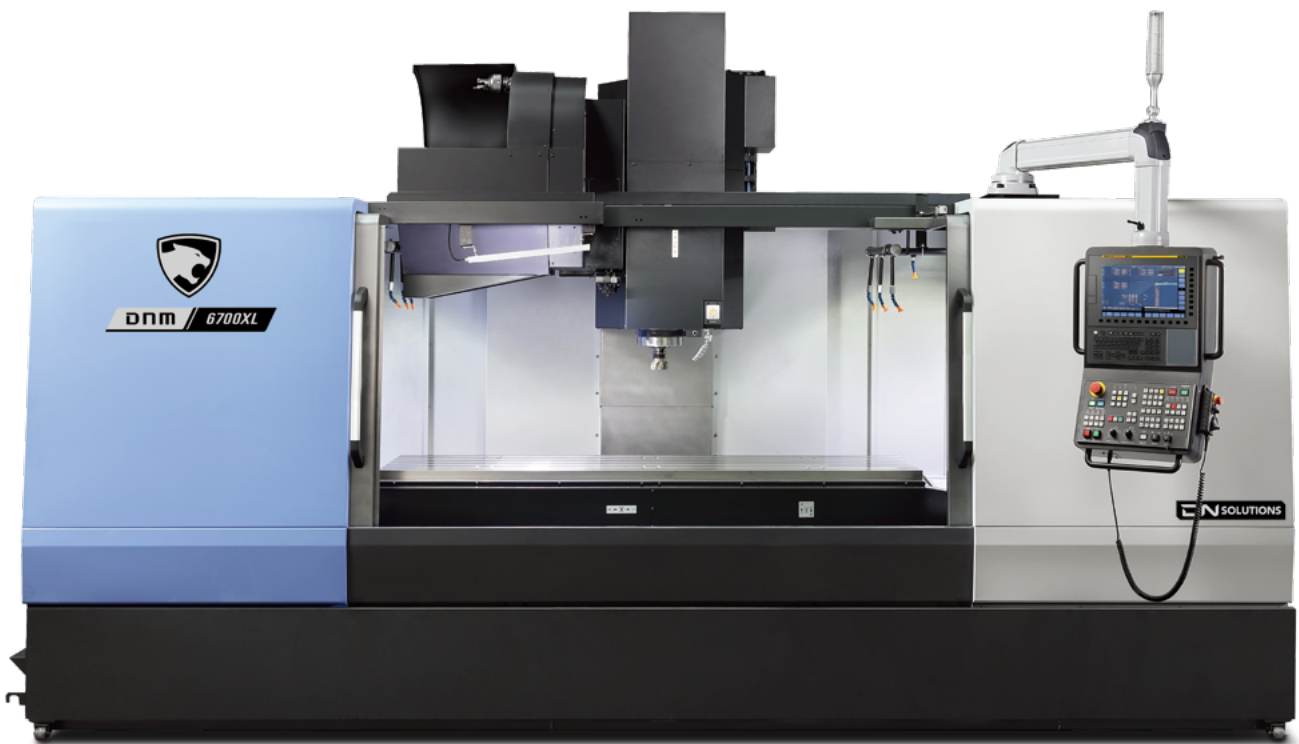

Standard features include the largest machining envelope in its class, direct coupled spindles, roller guideways and thermal compensation to deliver high precision.



**A HIGHLY VERSATILE VERTICAL MACHINING CENTER WITH THE LARGEST MACHINING ENVELOPE IN ITS CLASS**

- DNM series machines have larger tables with increased Y-axis travels and increased maximum table loads.
- DNM machines with longer X-axes (i.e., DNM 4500L, 5700L, 6700L/XL), are available.

**STANDARD DIRECT-COUPLED SPINDLE FOR HIGHER PRODUCTIVITY**

- Directly coupled spindles reduce vibration and noise, thereby improving the machines' performance and making them more environmentally-friendly compared to belt driven machines.
- High-torque and high speed spindles are available for the machining of different materials.
- Higher productivity is achieved by reducing tool change times and by improving acceleration and deceleration rates.

**AN ENVIRONMENTALLY-FRIENDLY MACHINE DESIGNED FOR STABLE AND EASY OPERATION**

- Thermal error compensation system supplied as standard optimizes machine accuracy by reducing the effects of heat build-up during extended periods of operation.
- The EZ work function can be checked in the pop-up window on the NC main screen for convenience.
- Grease lubrication for the axis roller guideways is a standard feature and helps reduce contamination.

# BASIC STRUCTURE

Designed with a highly stable and rigid structure, the new DNM series provides customers with machines with different Y-axis capabilities (from 450mm to 670mm), enabling the machining of a wider range of workpieces.

## Travel distance (X / Y / Z axis)

DNM 4500/L

**800{910} / 450 / 510** mm

31.5{35.8} / 17.7 / 20.1 inch

DNM 5700/L

**1050{1300} / 570 / 510** mm

41.3{51.2} / 22.4 / 20.1 inch

DNM 6700/L/XL

**1300{1500/2100}**  
**/ 670 / 625** mm

51.2{59.1/82.7}

/ 26.4 / 24.6 inch

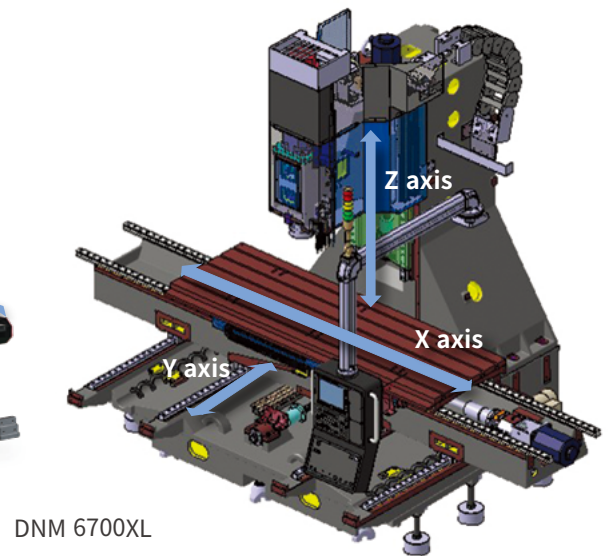
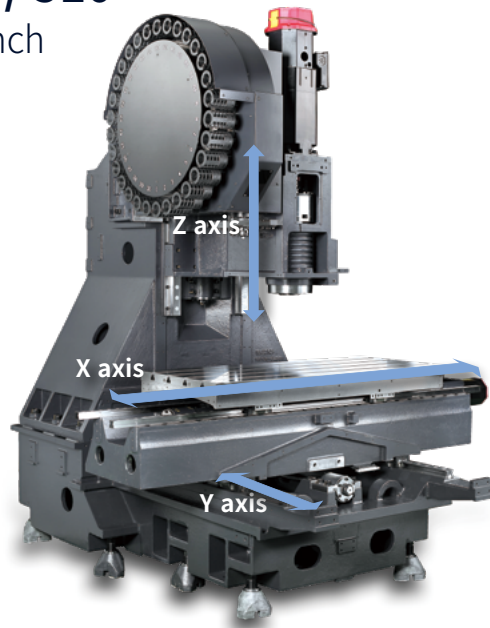

## Axis system

Environmentally-friendly grease lubrication is adopted as standard for all the axis feed systems, and roller-type LM guides are used to enhance rigidity.

## Rapid traverse rate (X / Y / Z axis)

DNM 4500 / 5700 / 6700 / 6700L

**36 / 36 / 30** m/min

(1417.3 / 1417.3 / 1181.1 ipm)

DNM 6700XL

**30 / 30 / 30** m/min

(1181.1 / 1181.1 / 1181.1 ipm)

Roller-type LM Guides are provided as a standard feature.

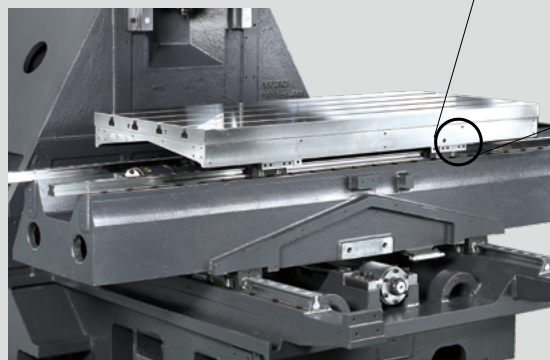

Grease lubrication for all axes is a standard feature.



# SPINDLE | TABLE

Directly-coupled spindles have been adopted as a standard feature to further reduce vibration and noise and enhance productivity, increase accuracy and improve the working environment. High-torque and high speed spindle options for machining different materials are available.

## Max. spindle speed

**8000** r/min

**12000** r/min option

**15000** r/min option

## Max. spindle motor power

**18.5** kW 24.8 Hp

## Max. spindle motor torque

**117.8** N·m 86.9 lbf-ft  
(8000 r/min, 12000 r/min,  
15000 r/min)

**286** N·m 211.1 lbf-ft option  
(8000 r/min high torque  
version)

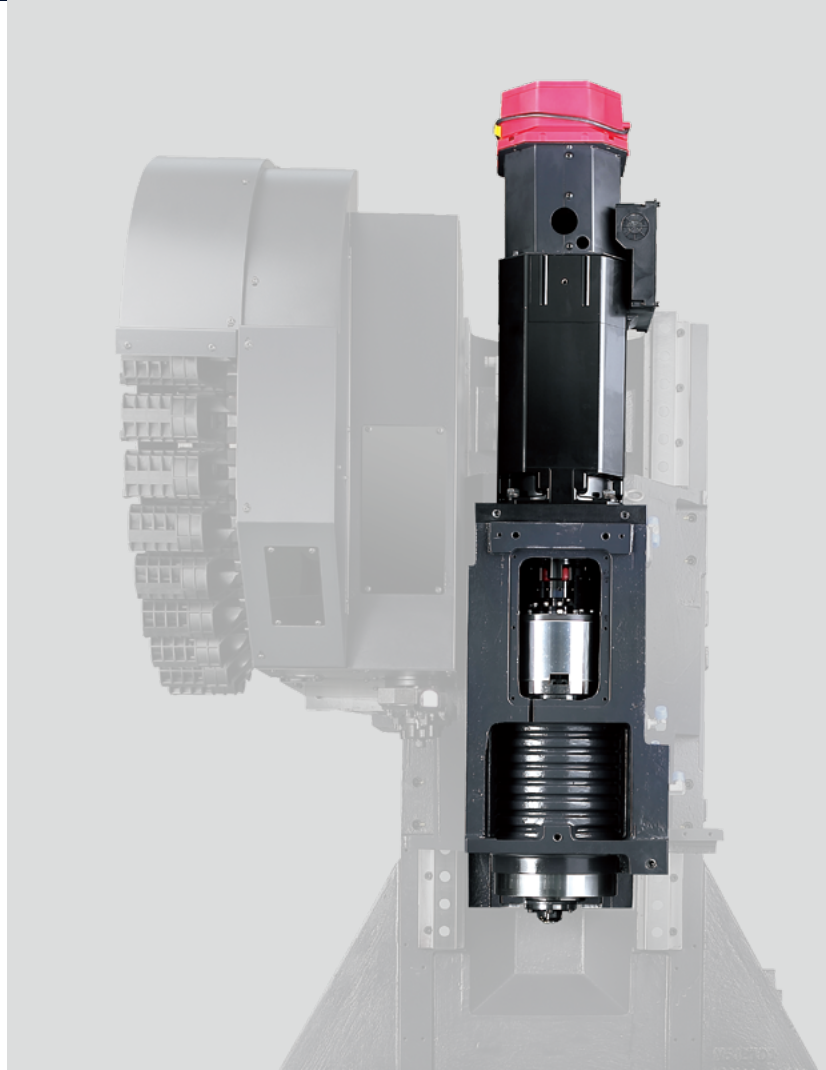

# TABLE

Increased table sizes and table load capacities are provided within the same floor space of the previous models.

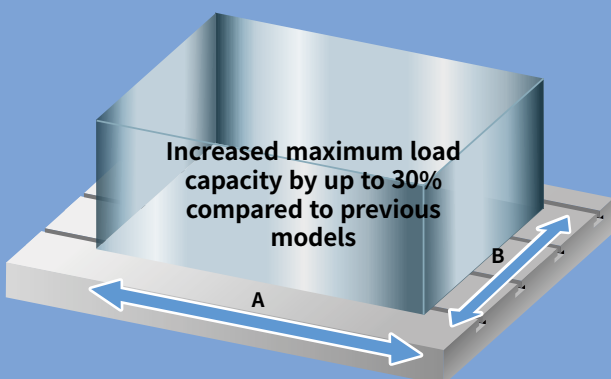

## Table size (A x B)

DNM 4500/L

**1000/1050** x **450** mm

39.4{41.3} x 17.7 inch

DNM 5700/L

**1300/1500** x **570** mm

51.2{59.1} x 21.3 inch

DNM 6700/L/XL

**1500/1600/2200** x **670** mm

59.1{63.0/86.6} x 26.4 inch

## Max weight on Table

DNM 4500/4500L

**600** kg 1322.8 lb

DNM 5700/5700L

**1000** kg 2204.6 lb

DNM 6700/6700L/6700XL

**1300** kg 2866.0 lb

# MACHINING PERFORMANCE

The DNM series delivers the best cutting performance in its class and ensures highest levels of productivity.

## Cutting performance

High-rigidity machining can be undertaken with speed and precision.

<b>Face mill (ø80mm (3.15 inch)) Carbon steel (SM45C)</b>			
Chip removal rate cm <sup>3</sup> /min (inch <sup>3</sup> /min)	Spindle speed r/min	Feedrate mm/min (ipm)	
527 (32.2)	1500	2700 (106.3)	
<b>Face mill (ø80mm (3.15 inch)) Aluminium(AL6061)</b>			
Chip removal rate cm <sup>3</sup> /min (inch <sup>3</sup> /min)	Spindle speed r/min	Feedrate mm/min (ipm)	
1901 (116.0)	1500	5940 (233.9)	
<b>End mill (ø30mm (i.2 inch)) Carbon steel (SM45C)</b>			
Chip removal rate cm <sup>3</sup> /min (inch <sup>3</sup> /min)	Spindle speed r/min	Feedrate mm/min (ipm)	
48 (2.9)	222	107 (4.2)	
<b>U-Drill (ø50mm (2.0 inch)) Carbon steel (SM45C)</b>			
Chip removal rate cm <sup>3</sup> /min (inch <sup>3</sup> /min)	Spindle speed r/min	Feedrate mm/min (ipm)	
501 (30.6)	1500	255 (10.0)	
<b>Tap Carbon steel (SM45C)</b>			
Tap size mm	Spindle speed r/min	Feedrate mm/min (ipm)	
M 36 x P 4.0	221	884 (34.8)	

\*The results, indicated in this catalogue, are provided as examples only. They may not always be achieved owing to different cutting and environmental conditions.

## High Productivity

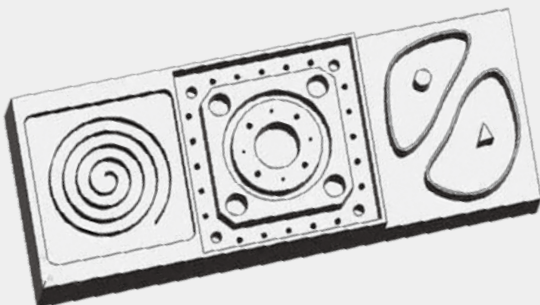

### Sample work

Material	Aluminium (AL6061)
Material size	561 x 210 x 30 mm (22.1 x 8.3 x 1.2 inch)
Using tools	18 ea

	Non-cutting time	Cutting time	Run hours
Previous model	14min. 31sec.	37min. 20sec.	51min. 51sec.
	Reduced by <b>17%</b>		Reduced by <b>5%</b>
New DNM series	12min. 6sec.	37min. 20sec.	49min. 26sec.

\*The results, indicated in this catalogue, are provided as examples only. They may not always be achieved owing to different cutting and environmental conditions.

# TOOL CHANGE SYSTEM

Tool changers have been optimized to reduce non cutting times. The highly-reliable tool magazine can accommodate up to 30 tools as standard.

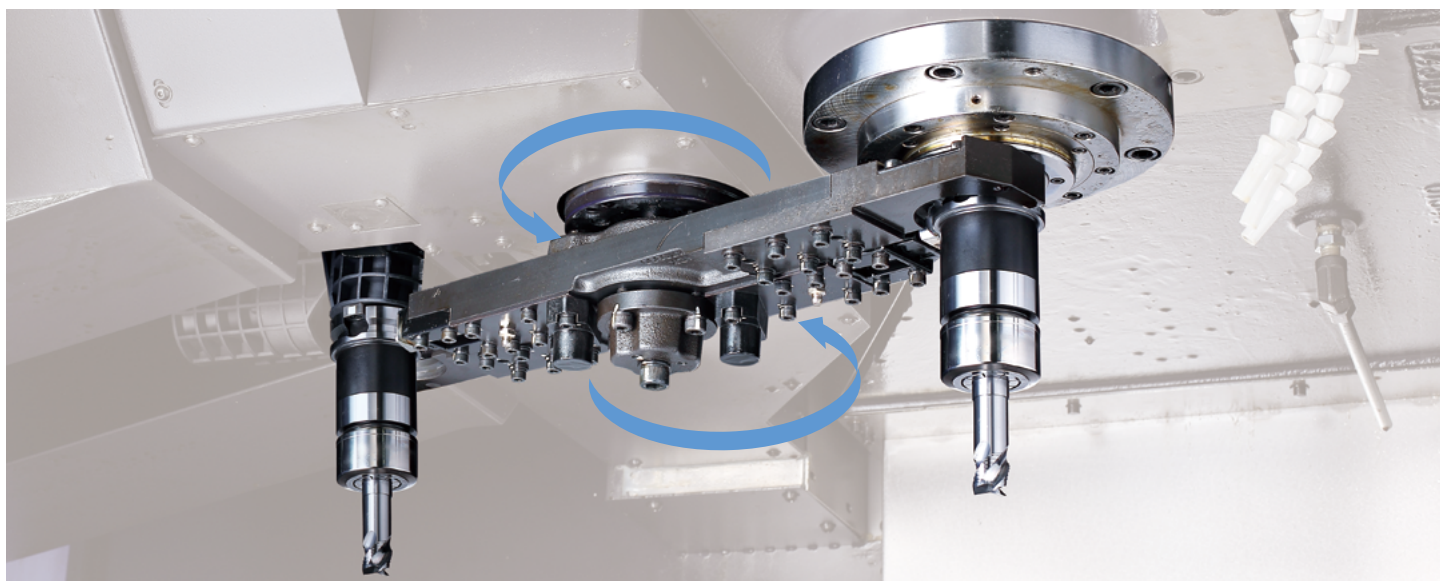

30, 40 ea

## Tool to Tool time

---

**1.2 S**

## Chip to Chip\* time

---

**3.2 S**

\* The Chip-to-Chip time has been tested in accordance with DN Solutions's strict testing procedures, but may vary depending on the user's operating conditions.

## Tool storage capacity

---

**30** ea

**40** ea option

**60** ea option



60 ea

# STANDARD | OPTIONAL SPECIFICATIONS

Various optional features are available to meet customers' specific machining requirements and applications.

Description	Features	DNM 4500/L	DNM 5700/L	DNM 6700/6700L/XL			
Spindle	8000 r/min (Unit: kW(Hp), N·m(lbf-ft))	18.5/11(24.8/14.8), 117.8(86.9)_FANUC	●	●	X		
		18.5/15 (24.8/20.1), 117.8(86.9)_FANUC	X	X	●		
		15/11 (20.1/14.8), 286(211.1)_FANUC	○	○	○		
	12000 r/min (Unit: kW(Hp), N·m(lbf-ft))	18.5/11(24.8/14.8), 117.8(86.9)_FANUC	○	○	○		
		17/10 (22.8/13.4), 108.6(80.1)_HEIDENHAIN	○	○	X		
		32/15 (42.9/20.1), 203.7(150.3)_HEIDENHAIN	X	X	○		
		16.5/11 (22.1/14.8), 141(104.1)_SIEMENS	○	○	X		
		21.8/16.3 (29.2/21.9),150.1(110.8)_SIEMENS	X	X	○		
		18.5/11(24.8/14.8), 117.8(86.9)_FANUC	○	○	○		
	15000 r/min (Unit: kW(Hp), N·m(lbf-ft))	17/10 (22.8/13.4), 108.2 (79.9)_HEIDENHAIN	○	○	○		
		16.5/11 (22.1/14.8), 141.3 (104.3)_SIEMENS	○	○	○		
		30 ea	●	●	●		
Magazine	Tool storage capacity	○	○	○			
	40 ea	○	○	○			
	60 ea	○	○	○			
Tool shank type	BIG PLUS BT40	●	●	●			
	BIG PLUS CAT40	○	○	○			
	BIG PLUS DIN40	○	○	○			
Raised column	150 mm (5.9 inch)	○	○	○			
	200 mm (7.9 inch)	○	○	○			
	300 mm (11.8 inch)	○	○	○			
Coolant	FLOOD	0.19 MPa(27.6 psi), 0.4 kW(0.5 Hp)	●	●	●		
		0.69 MPa(100.1 psi), 1.8 kW(2.4 Hp)	○	○	○		
	TSC**	None	●	●	●		
		2 MPa(290.1 psi), 1.5kW(2.0 Hp)	○	○	○		
		2 MPa(290.1 psi), 4 kW(5.4 Hp)	○	○	○		
		7 MPa(1015.3 psi), 5.5 kW(7.4 Hp)	○	○	○		
	FLUSHING		○	○	○		
SHOWER (200 L/min (52.8 gal/min))		○	○	○			
Chip disposal	Chip conveyor	Chip pan	●	●	●		
		Hinged type (Left/Right/Rear)	○	○	○		
		Magnetic scraper type (Left/Right/Rear)	○	○	○		
		Screw(AUGER) type (Left/Right)	○	○	○		
	Chip bucket		○	○	○		
Precision machining option	Linear scale	X / Y / Z axis	○	○	○		
	AICC II (200 block)		●	●	●		
	SSP (Smooth Surface Package)		○	○	○		
Measurement & Automation	Automatic tool measurement	TS27R_RENISHAW	○	○	○		
		OTS_RENISHAW	○	○	○		
	Automatic tool breakage detection		○	○	○		
	Automatic workpiece measurement	OMP60_RENISHAW	○	○	○		
	Automatic front door with safety device		○	○	○		
Accessories	WORK LIGHT	LED LAMP	●	●	●		
	OPERATOR CALL LAMP	3-COLOR SIGNAL TOWER(LED)	●	●	●		
	LEVELING BLOCK & BOLT	-	●	●	●		
	SMART THERMAL CONTROL	SENSORLESS TYPE(ONLY SPINDLE)	●	●	●		
	ASSEMBLY & OPERATION TOOLS KIT	-	●	●	●		
	4TH AXIS PREPARATION CABLING FOR SERVO/1-PNEUMATIC PIPING	FACTORY READY MADE	○	○	○		
	AIR GUN		○	○	○		
	Air blower		○	○	○		
	Coolant gun		○	○	○		
	Mist collector		○	○	○		
Customized Special Option	ANCHORING <sup>(1)</sup>	SLIDE CLAMP & CHEMINCAL ANCHOR BOLT	○	○	○		
	TSA <sup>(2)</sup>	0.54	○	○	○		
	TOOL TYPE	HSK63A	○	○	○		
	ATC AUTO SHUTTER	30TOOL / 40TOOL	○	○	○		
	ATC FULL COVER	30TOOL / 40TOOL	○	○	○		
	Drum chipconveyor	HINGE TYPE		○	○	○	
		SCRAPER TYPE		○	○	○	
	Oil lubrication	X, Y, Z AXIS	○	○	○		
	20 Bar TSC with inverter	50Hz → 60Hz	○	○	○		
	FINE DUST PROTECTING PACKAGE	WET MACHINING	BELLOWS COVER(X/Y/Z)	○	○	○	
			PROTECT COVER(X-AXIS)	○	○	○	
			BALL SCREW BELLOWS COVER(X/Y)	○	○	○	
			GUIDE WAY DOUBLE WIPER	○	○	○	
		DRY MACHINING	PROTECT COVER(X-AXIS)		○	○	○
			BALL SCREW BELLOWS COVER(X/Y)		○	○	○
			GUIDE WAY DOUBLE WIPER		○	○	○
			AIR OIL SUCTION(ONLY 15k SPINDLE)		○	○	○
	AUTO TOOL LENGTH MEASUREMENT	RENISHAW / LTS	○	○	○		
	AUTO TOOL BREAKAGE DETECTION	MSC/BK9(NEEDLE TYPE ON MAGAZINE)	○	○	○		

\* Please contact DN Solutions for detailed specification information.

\*\* If this option is selected, the TSA(Through Spindle Air) Max.pressure is 0.54MPa

(1) Please refer to foundation drawing in relation to anchoring. If more detailed information is required consult with DN Solutions service

(2) If TSC is not required - TSA can be selected as an option.

● Standard ○ Optional X Not applicable



# PERIPHERAL EQUIPMENT

## Grease lubrication system

The standard grease lubrication system eliminates the need for an oil skimmer and reduces lubrication costs by about 60% compared to oil lubrication.

### Yearly maintenance cost

Reduced by  
Max. **60%**



## Raised column option

When the distance between the table and the spindle nose needs to be extended, for example, to accommodate a fixture or a rotary table, the solid one-piece raised column can be raised to increase the distance required.

Height  
**150/200/300 mm**  
5.9/7.9/11.8 inch

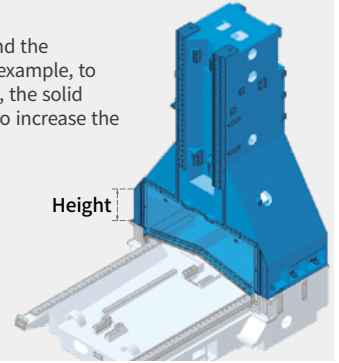

## Chip conveyor option

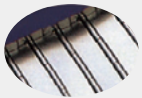

Hinged belt



Magnetic scraper

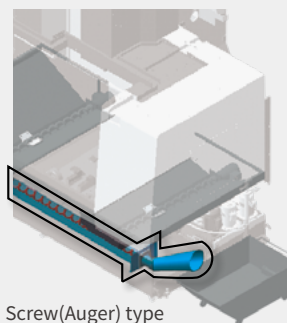

Screw(Auger) type

## Chip bucket option

Capacity **300 L** (79.3 gal)



Chip conveyor type	Material	Description
Hinged belt	Steel	Hinged belt chip conveyor, which is most commonly used for steel work [for cleaning chips longer than 30mm(1.2inch)], is available as an option.
Magnetic scraper	Cast Iron	Magnetic scraper type chip conveyor, which is ideal for die-casting work [for cleaning small chips], is available as an option.
Screw(Auger) type	Steel	Screw(Auger) type chip conveyor is suitable for minimizing installation space. About 85% floor space is required to install Screw(Auger) type chip conveyor compared to Hinged belt type.

## Hydraulic / Pneumatic fixture line option

The user should prepare pipelines for hydraulic/pneumatic fixtures whose detailed specifications should be determined through discussions with DN Solutions.



### Pneumatic

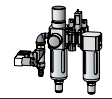

### Hydraulic

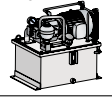

## 4 axis rotary table option

The high-precision split system with its compact and highly rigid design, and double piston structure enables vertical and horizontal use and delivers a strong clamping force.



## ATC shutter door option

An ATC shutter door can be applied instead of the brush mechanism to provide a higher level of protection from potential chip ingress.

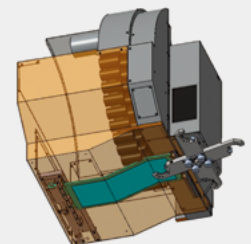

## AWC system option

A compact automatic workpiece change system



Max. workpiece dimensions	Unit	Count	Max. loading	Max. construction height on the pallet
250 x 250 (9.8x9.8) or ø 300 (11.8)	mm (inch)	12	130kg (286.6lb)	350mm (13.8inch)
320 x 320 (12.6x12.6) or ø 360 (14.2)	mm (inch)	10	250kg (551.1lb)	
350 x 350 (13.8x13.8) or ø 400 (15.7)	mm (inch)	8		
400 x 400 (15.7x15.7) or ø 450 (17.7)	mm (inch)	6		
500 x 500 (19.7x19.7) or ø 550 (21.7)	mm (inch)	4		

## Pallet Storage-Table Configuration

Unit : mm (inch)

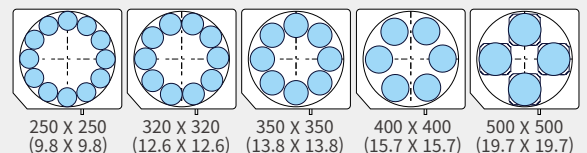
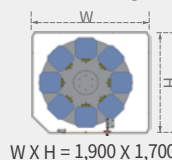

# DN SOLUTIONS FANUC i PLUS

DN Solutions Fanuc i Plus is optimized for maximizing customer productivity and convenience.

## 15 inch screen + new operation panel

DN Solutions Fanuc i Plus' operation panel enhances operating convenience by incorporating common-design buttons and layout, and features the Qwerty keyboard for fast and easy operation.

## DN Solutions Fanuc i Plus

- 15 inch color display
- Intuitive and user-friendly design

## USB & PCMCIA card

## QWERTY keyboard

- EZ-guide i standard
- Ergonomic operator panel
- 2MB Memory
- Hot key



## iHMI touchscreen option

iHMI provides an intuitive interface that uses a touchscreen for quick and easy operation.

## Range of applications

Providing various applications related to planning, machining, improvement and utility, for customer convenience.

# NUMERIC CONTROL SPECIFICATIONS

**FANUC**

Item	Specifications	DN Solutions Fanuc i (0i Plus) DNM 4digit
Controlled axis	Controlled axes	3 (X,Y,Z)
	Simultaneously controlled axes	4 axes
	Additional controlled Axis	●
Data input/output	Fast data server	○
	Memory card input/output	●
	USB memory input/output	●
	Large capacity memory(2GB)*2	○
Interface function	Embedded Ethernet	●
	Fast Ethernet	○
	Enhanced Embedded Ethernet function	●
Operation	DNC operation	●
	DNC operation with memory card	●
Program input	Workpiece coordinate system	G52 - G59
	Addition of workpiece coordinate system	G54.1 P1 X 48 (48 pairs)
	Tool number command	T4 digits
	Tilted working plane indexing command	G68.2 TWP
Feed function	AI contour control I	G5.1 Q_, 40 Blocks
	AI contour control II	G5.1 Q_, 200 Blocks
	AI contour control II	G5.1 Q_, 600 Blocks
	AI contour control II	G5.1 Q_, 1000 Blocks *1)
	High smooth TCP	X
Operation guidance function	EZ Guidei (Conversational Programming Solution)	●
	iHMI with Machining Cycle	Only with 15" Touch LCD standard *2)
Setting and display	EZ Operation package	●
	CNC screen dual display function	●
Network	FANUC MTConnect	⊕
	FANUC OPC UA	⊕
Others	Display unit	10.4" color LCD
		15" color LCD
	Part program storage size & Number of registerable programs	15" color LCD with Touch Panel
		640M(256KB)_ 500 programs
		1280M(512KB)_ 1000 programs
		2560M(1MB)_ 1000 programs
		5120M(2MB)_ 1000 programs
		10240M(4MB)_ 1000 programs
		20480M(8MB)_ 1000 programs
		2560M(1MB)_ 2000 programs
		5120M(2MB)_ 4000 programs
		10240M(4MB)_ 4000 programs
		20480M(8MB)_ 4000 programs

\*1) The number of look-ahead blocks may be changed or limited depending on the peripheral device or the configuration of the internal NC system.

\*2) Available Option only with Fanuc i plus iHMI

● Standard ○ Optional X N/A ⊕ Available  
Network: FANUC MT Connect and FANUC OPC UA available.

# EZ WORK

The software developed by DN Solutions provides a range of different functions designed for fast, efficient and convenient operation.

## EZ work

The EZ work package delivers speed and efficiency. This menu-driven innovation not only helps customers reduce setup times, but also simplifies common tasks and procedures, reducing the potential for errors. EZ work reduces operating time, protects machinery, enhances quality and speeds up maintenance interventions.

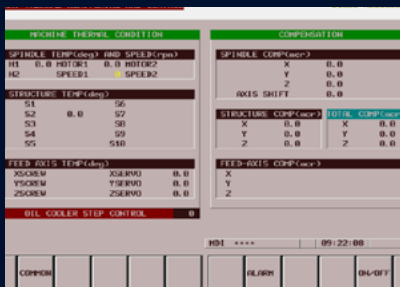

### Thermal Compensation

A function to maintain high-precision machining quality by analyzing and correcting the amount of thermal displacement of a structure through a temperature sensor



### M/G-Code List

Functional description of M code and G code



### Tool Management

Function to manage tool information [Tool information / Tool No. / Tool condition (normal, large diameter, worn / damaged, used for the rst time, manual) / Tool name]

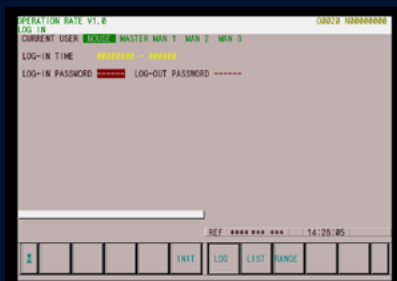

### Operation Rate

Machine operation history management function by date based on load



### Adaptive Feed Control

Function to control feedrate so that the cutting can be carried out at a constant load (To adapt to the spindle load set up with constant load feedrate control function)

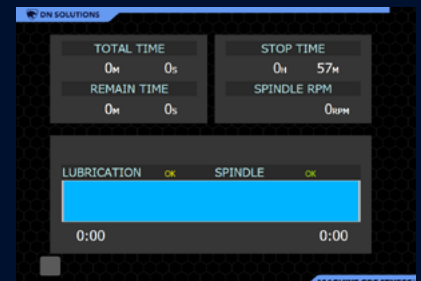

### Spindle Warm Up

A function that assists spindle warm-up for spindle life when the spindle has not been used for a certain period of time



### ATC Recovery

Function to view detailed info with recommended actions and to perform step-by-step operation manually (when an alarm is triggered during an ATC operation)

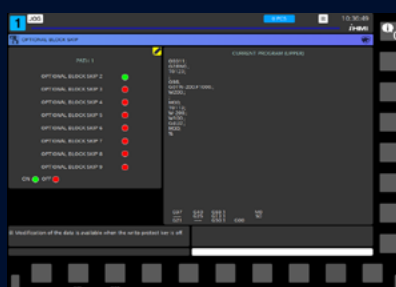

### Addition of Optional Block Skip

In addition to the OPTIONAL BLOCK SKIP of the operation panel, the function to skip a specific block selected in the machining program

# CONVENIENT OPERATION

## HEIDENHAIN TNC620

### Superior hardware specifications

The TNC 620 features optimized motion control, short block processing times and special control strategies. Together with its uniform digital design and its integrated digital drive control (including inverters), it enables you to achieve high machining speeds and the best possible contour accuracy.

- 15.6" display
- 21GB Storage memory
- 1024 look ahead blocks
- High user convenience with folder structure data management

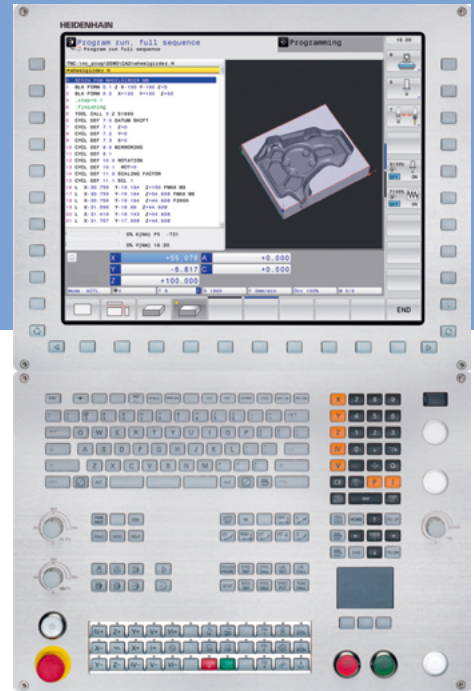

### Conversational convenient function

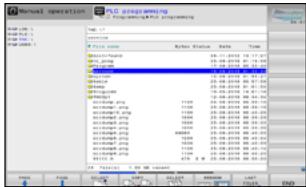

Data are controlled in the folder structure; convenient communication via USB devices



KinematicOpt & KinematicComp option  
(Touch probe cycle for automatic measurement)

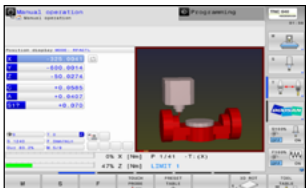

Collision protection system option

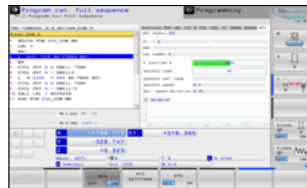

Adaptive feed control option



Various built-in pattern cycles for a wider scope of application (Software standard)

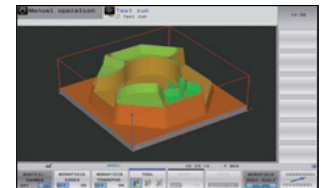

Graphic simulation

## NUMERIC CONTROL SPECIFICATIONS



HEIDENHAIN

Item		Specifications	TNC620 DNM
Controlled axis	Controlled axis		3 (X,Y,Z)
	Simultaneously controlled axis		4 axis
Data input/output	USB memory input/output		●
Interface function	Embedded ethernet		●
Feed function	Look-ahead	5000 blocks	●
Axis compensation	KinematicsOpt	Automatic measurement and optimization of machine kinematics	○
Collision monitoring	Dynamic collision monitoring (DCM)		X
Network	MTConnect		⊕
Others	Display unit	15" color LCD	●
		15" color LCD with touch panel	○
	Part program storage size & number of registerable programs	1.8GB	●

● Standard ○ Optional X Not Available ⊕ Available



# CONVENIENT OPERATION

## SIEMENS 828D

### 15.6" screen + new operation panel

The newly-designed operation panel improves the customer convenience by incorporating and using common-design buttons and layouts, and includes the familiar QWERTY keyboard for fast and easy operation.

- 15.6" display
- 10MB high capacity user memory
- USB & ethernet (standard)
- QWERTY keyboard (standard)
- High-speed calculation and simulation can be fulfilled by improved processor functionality



### Conversational convenient function

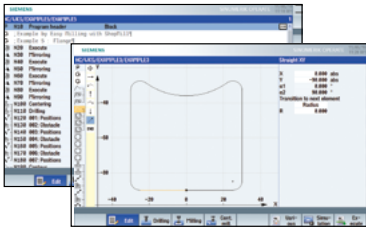

Shop Mill Part Programming

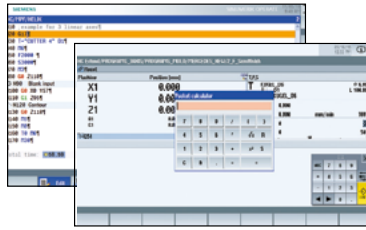

Smart function

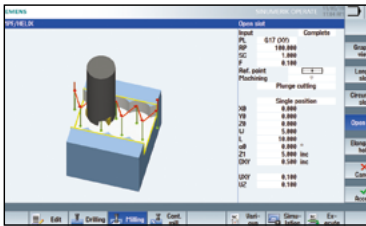

Advanced program language programGUIDE

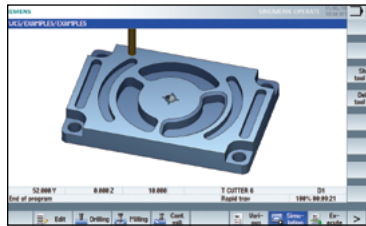

Simulation and machining contour monitoring

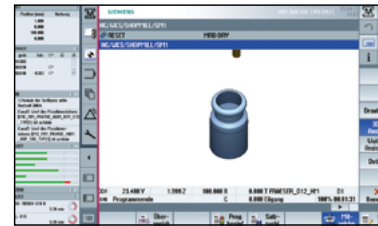

Side screen widget

## NUMERIC CONTROL SPECIFICATIONS

SIEMENS

Item	Specifications	S828D
		DNM
Controlled axis	Controlled axes ( 제어축수 )	-
	Simultaneously controlled axes ( 동시 제어축수 )	-
Data input/output	Memory card input/output	(Local drive)
	USB memory input/output	
Interface function	Ethernet	(X130)
Operation	On network drive	(without EES option, Extcall)
	On USB storage medium, e.g. memory stick	(without EES option, Extcall)
Program input	Workpiece coordinate system	G54 - G57
	Addition of workpiece coordinate system	G505 - G599
Interpolation & Feed function	Advanced surface	
	Top surface	
Programming & Editing function	Look ahead number of block	S/W version 4.8
	3D simulation, finished part	
Operation Guidance Function	Simultaneous recording	
	Measure kinematics	
Setting and display	DXF Reader for PC integrated in SINUMERIK Operate	
	ShopMill	
Network	EZ Work	
	Operation via a VNC viewer	
Etc. function	MTCConnect	
	OPCUA	
Etc. function	15.6" color display with touch screen	
	19" color display without touch screen	
	21.5" color display with touch screen	
	CNC user memory	10 MB
	Expansion by increments	2 ~ 12 MB
	Collision avoidance	
Collision avoidance ECO (machine, working area)		

# POWER | TORQUE

FANUC

## DNM 4500/L, DNM 5700/L

8000 r/min

Max. spindle power: 18.5 kW (24.8 Hp)

Max. spindle torque: 117.8 N·m (86.9 lbf-ft)

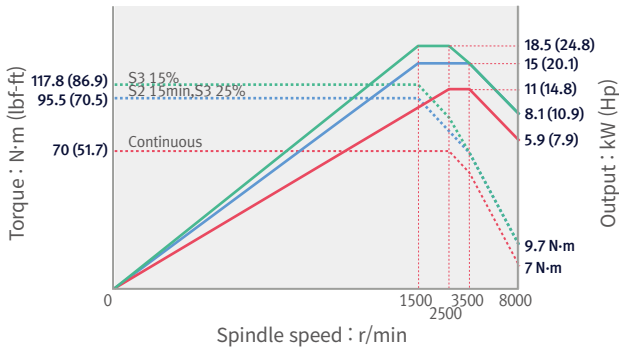

8000 r/min option

Max. spindle power: 15 kW (20.1 Hp)

Max. spindle torque: 286 N·m (211.1 lbf-ft)

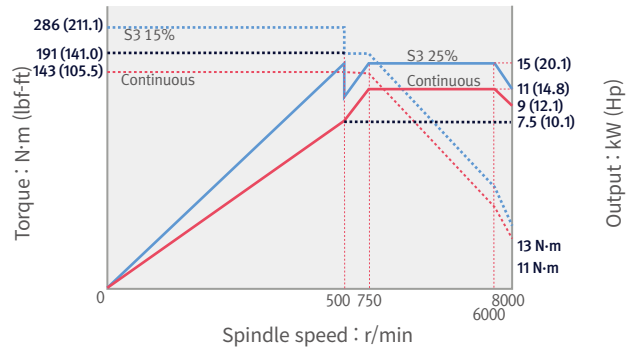

## DNM 6700/L/XL

8000 r/min

Max. spindle power: 18.5 kW (24.8 Hp)

Max. spindle torque: 117.8 N·m (86.9 lbf-ft)

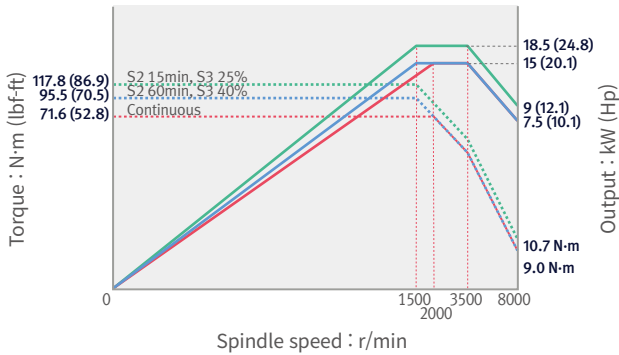

8000 r/min option

Max. spindle power: 15 kW (20.1 Hp)

Max. spindle torque: 286 N·m (211.1 lbf-ft)

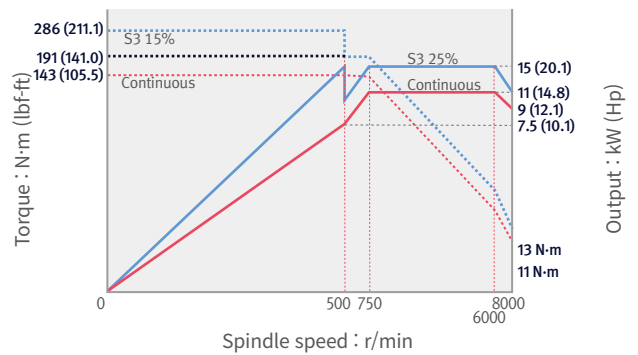

## DNM 4500/L, 5700/L, 6700/L/XL

12000 r/min option

Max. spindle power: 18.5 kW (24.8 Hp)

Max. spindle torque: 117.8 N·m (86.9 lbf-ft)

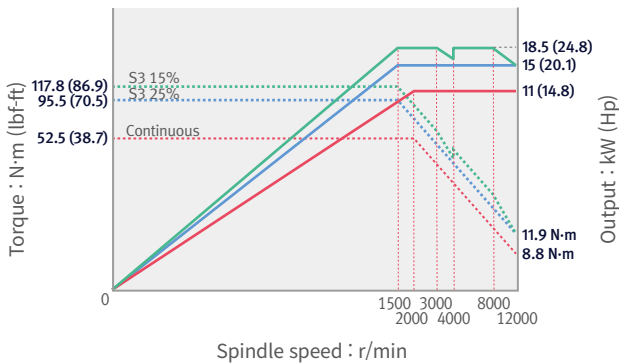

15000 r/min option

Max. spindle power: 18.5 kW (24.8 Hp)

Max. spindle torque: 117.8 N·m (86.9 lbf-ft)

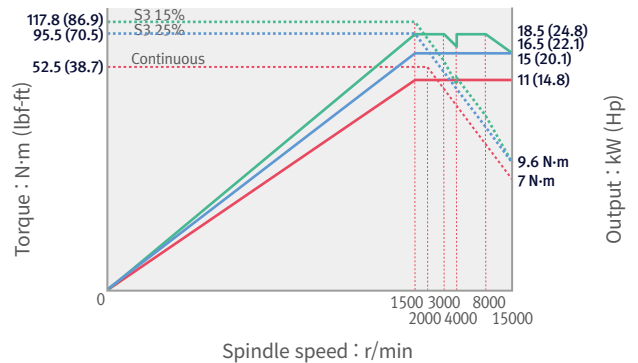

# POWER | TORQUE

SIEMENS

## DNM 4500/L, DNM 5700/L

12000 r/min

Max. spindle power: 16.5 kW (22.1 Hp)

Max. spindle torque: 141.3 N·m (104.3 lbf-ft)

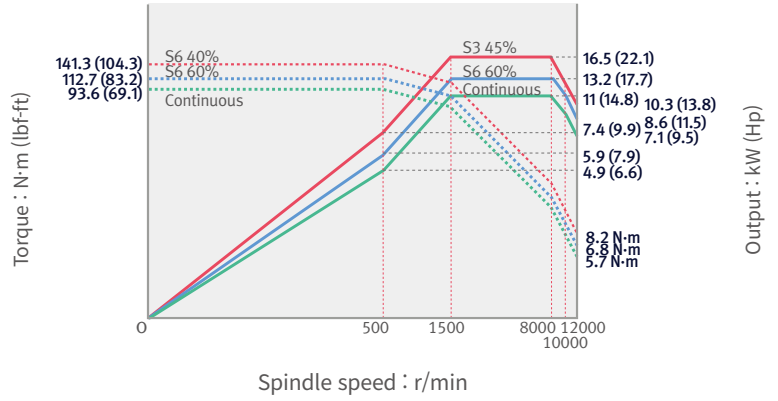

## DNM 6700/L/XL

12000 r/min

Max. spindle power: 21.8 kW (29.2 Hp)

Max. spindle torque: 150.1 N·m (110.8 lbf-ft)

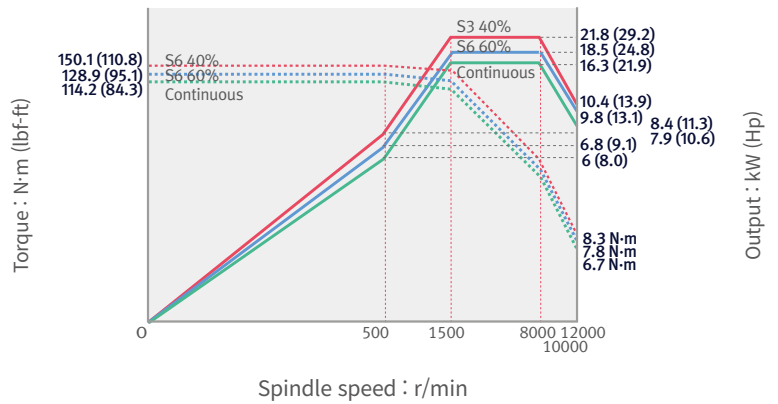

## DNM 4500/L, 5700/L, 6700/L/XL

15000 r/min

Max. spindle power: 16.5 kW (22.1 Hp)

Max. spindle torque: 141.3 N·m (104.3 lbf-ft)

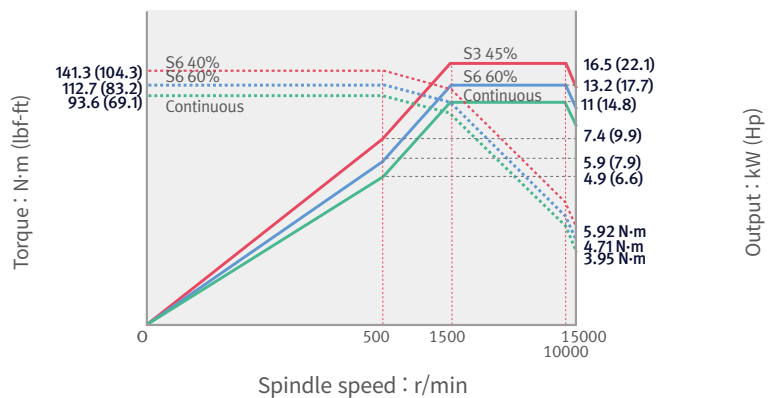

# POWER | TORQUE

HEIDENHAIN | MITSUBISHI

## HEIDENHAIN DNM 4500/L, DNM 5700/L

12000 r/min

Max. spindle power: 17 kW (22.8 Hp)

Max. spindle torque: 108.2 N·m (79.9 lbf-ft)

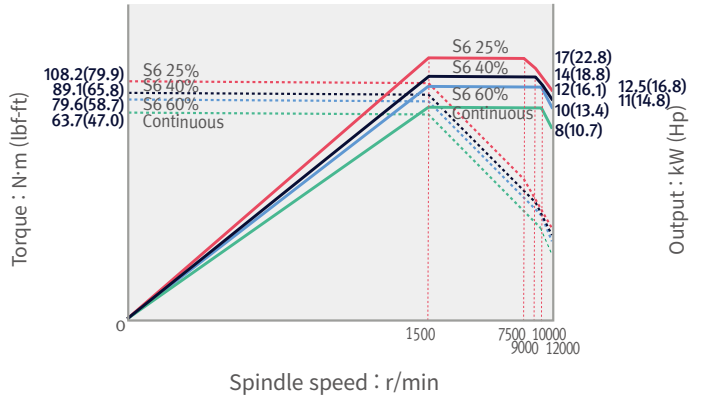

## HEIDENHAIN DNM 6700/L/XL

12000 r/min

Max. spindle power: 32 kW (42.9 Hp)

Max. spindle torque: 203.7 N·m (150.2 lbf-ft)

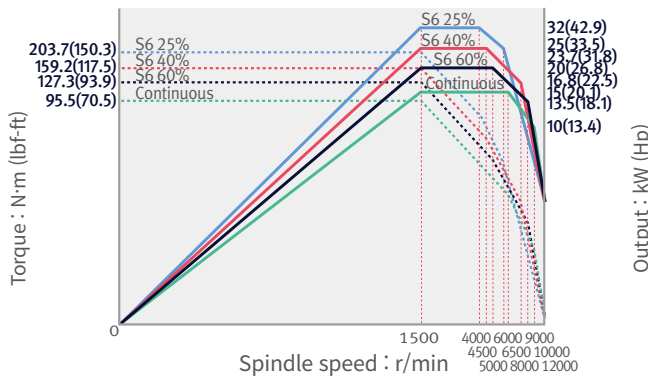

15000 r/min **option**

Max. spindle power: 17 kW (22.8 Hp)

Max. spindle torque: 108.2 N·m (79.9 lbf-ft)

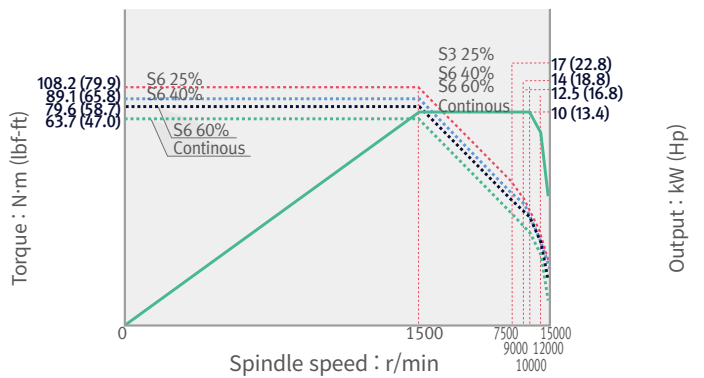

## MITSUBISHI DNM 4500/L, 5700/L, 6700/L/XL

12000 r/min **option**

Max. spindle power: 18.5 kW (24.8 Hp)

Max. spindle torque: 117.8 N·m (86.9 lbf-ft)

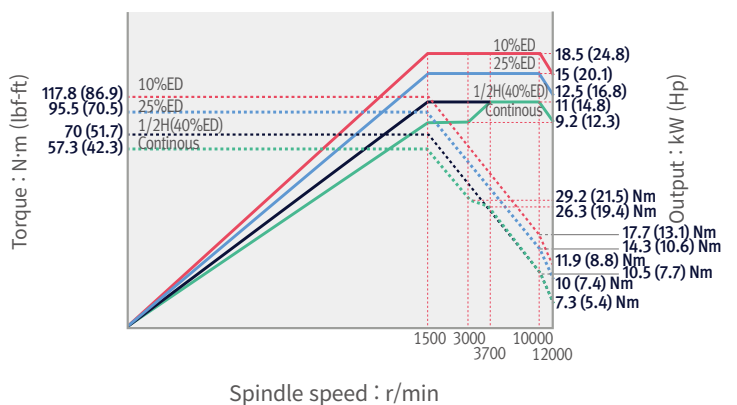



# DIMENSIONS

## DNM 4500/5700/6700 series

Units : mm (inch)

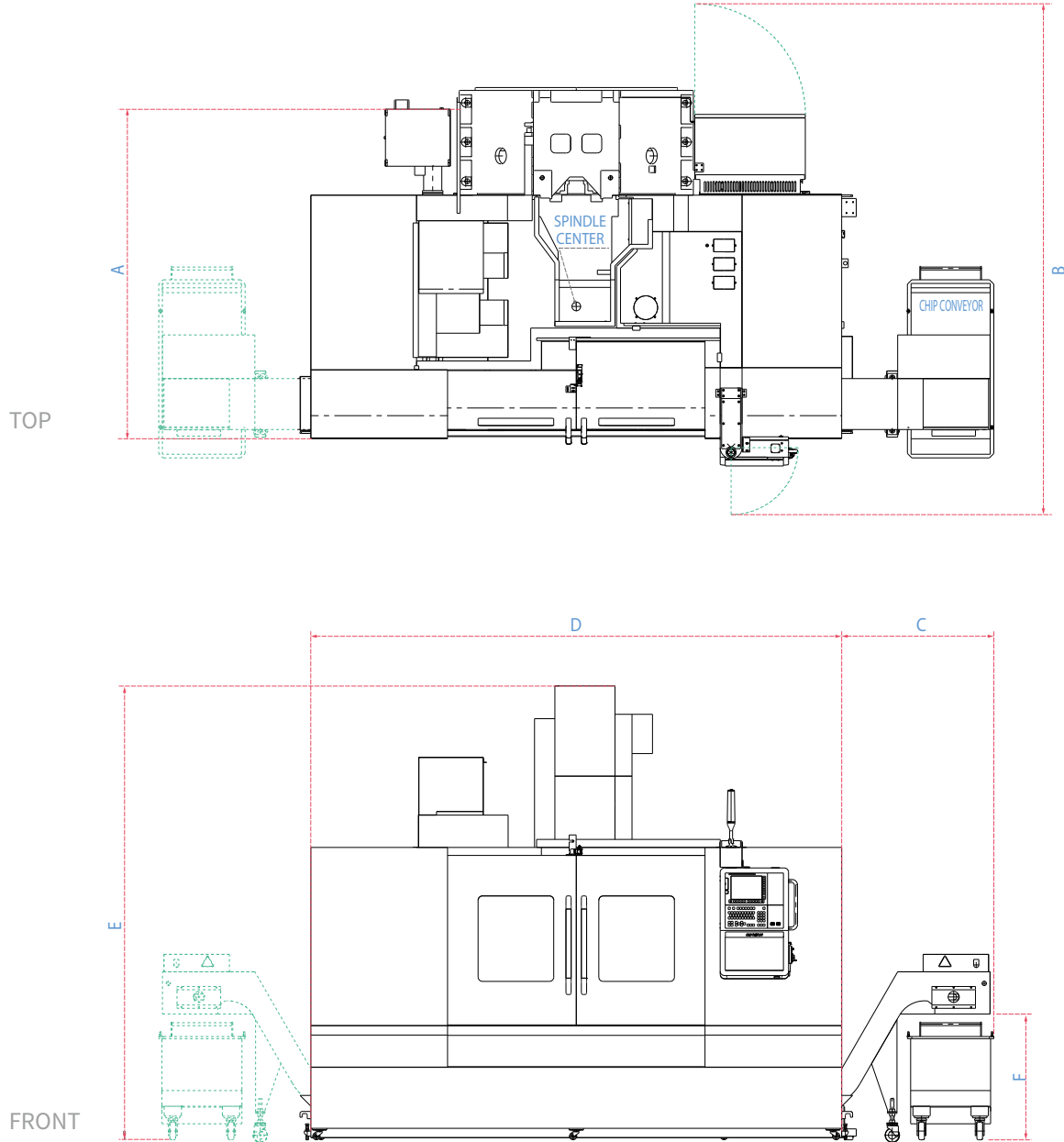

Model	A (Length)	B <sup>1</sup>	C <sup>2</sup>	D (Width)	E (Height)	F		
						SCRAPER	HINGED	SCREW
DNM 4500	1970 (77.6)	3200 (126.0)	1040 (415) [40.9(16.3)]	2465 (97.0)	2985 (117.5)	883 (34.8)	865 (34.1)	440 (17.3)
DNM 4500L	1970 (77.6)	3200 (126.0)	1040 (415) [40.9(16.3)]	2550(100.4)	2985 (117.5)	883 (34.8)	865 (34.1)	440 (17.3)
DNM 5700	2225 (87.6)	3365 (132.5)	1040 (415) [40.9(16.3)]	2960 (116.5)	2985 (117.5)	883 (34.8)	865 (34.1)	440 (17.3)
DNM 5700L	2225 (87.6)	3365 (132.5)	1040 (415) [40.9(16.3)]	3200 (126.0)	2985 (117.5)	883 (34.8)	865 (34.1)	440 (17.3)
DNM 6700	2415 (95.1)	3510 (138.2)	1040 (415) [40.9(16.3)]	3200 (126.0)	3120 (122.8)	883 (34.8)	865 (34.1)	440 (17.3)
DNM 6700L	2415 (95.1)	3510 (138.2)	1040 (415) [40.9(16.3)]	3650 (143.7)	3120 (122.8)	883 (34.8)	865 (34.1)	440 (17.3)

<sup>1</sup> Max. machine length (including electric cabinet door and operation panel swiveling)

<sup>2</sup> Additional width to accommodate the side chip conveyor. [ ] indicates the additional width required to accommodate a screw (auger) type chip conveyor.

\* Some peripheral equipment can be placed in other places \*Rear chip conveyor need discuss with sales person

# DIMENSIONS

## DNM 6700XL

Units : mm (inch)

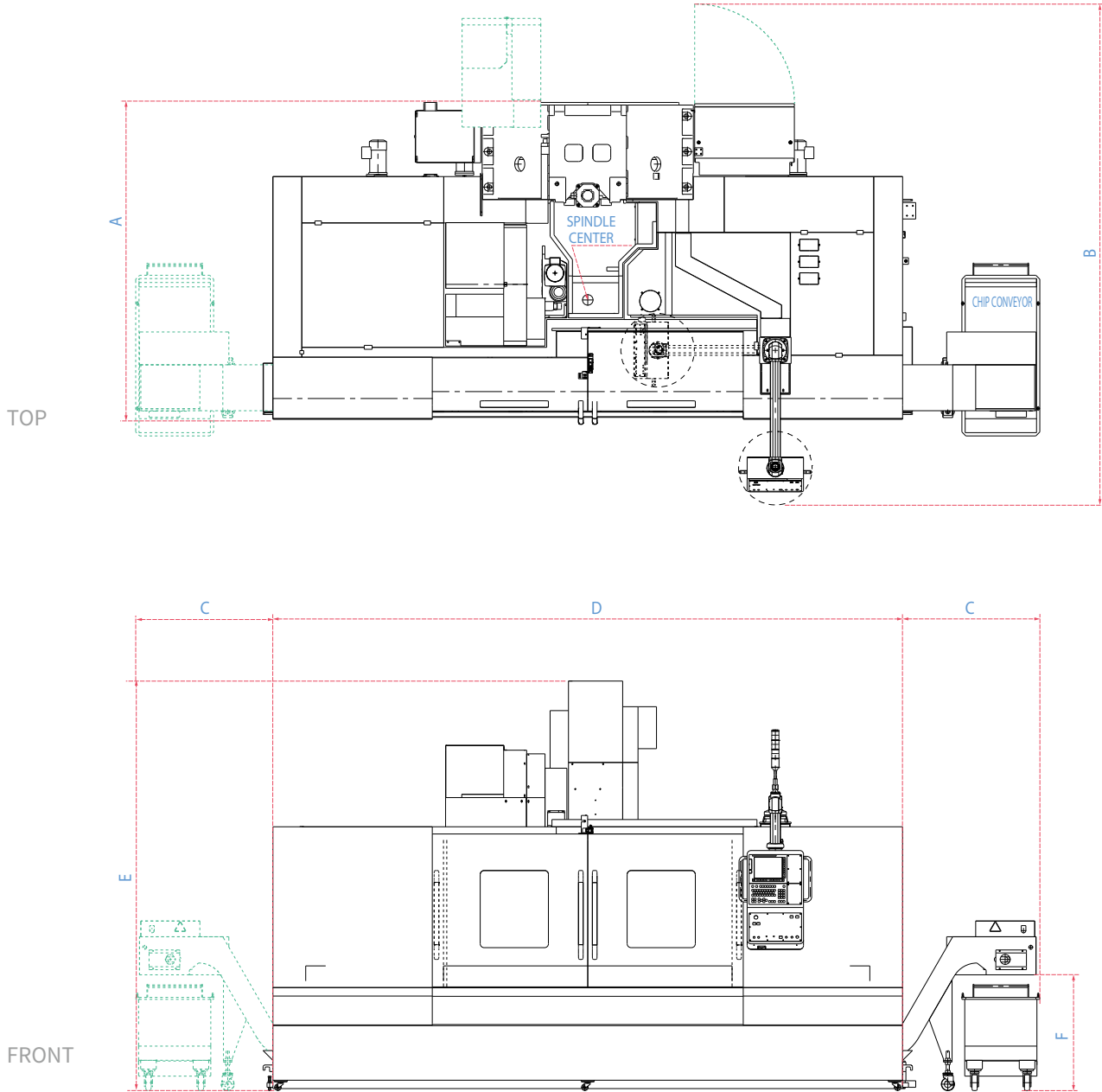

Model	A (Length)	B <sup>1</sup>	C <sup>2</sup>	D (Width)	E (Height)	F		
						SCRAPER	HINGED	SCREW
DNM 6700XL	2415 (95.1)	3820 (150.4)	1045 (41.1)	4800 (189.0)	3120 (122.8)	883 (34.8)	865 (34.1)	440 (17.3)

<sup>1</sup> Max. machine length (including electric cabinet door and operation panel swiveling)

<sup>2</sup> Additional width to accommodate the side chip conveyor. [ ] indicates the additional width required to accommodate a screw(auger)type chip conveyor.

\* Some peripheral equipment can be placed in other places \*Rear chipconveyor need discuss with sales person

# TABLE

## DNM 4500/L

Units : mm (inch)

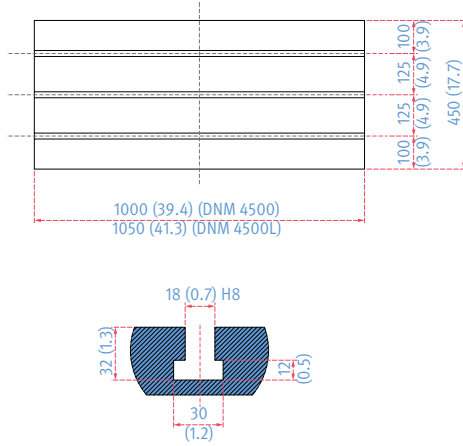

## DNM 5700/L

Units : mm (inch)

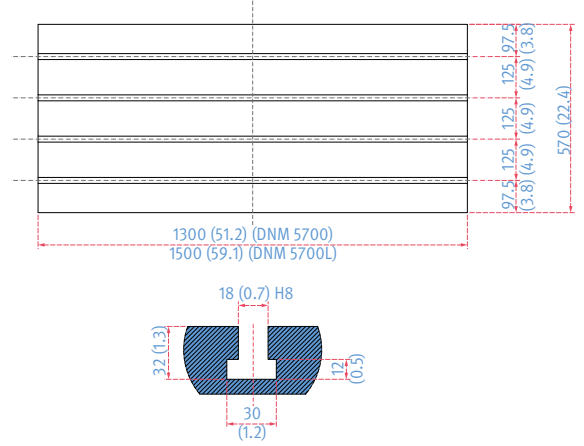

## DNM 6700

Units : mm (inch)

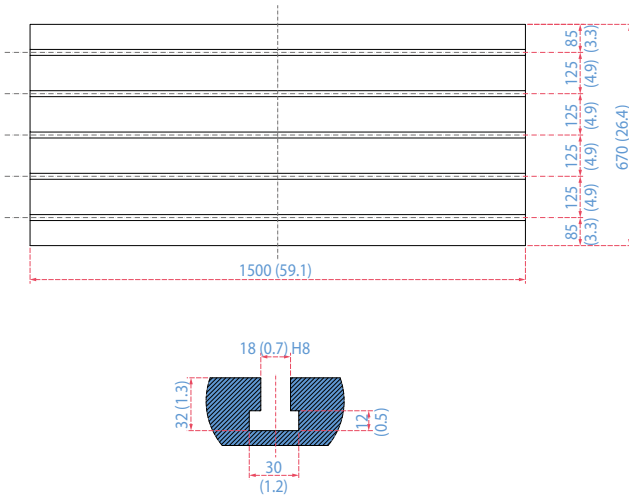

## DNM 6700L

Units : mm (inch)

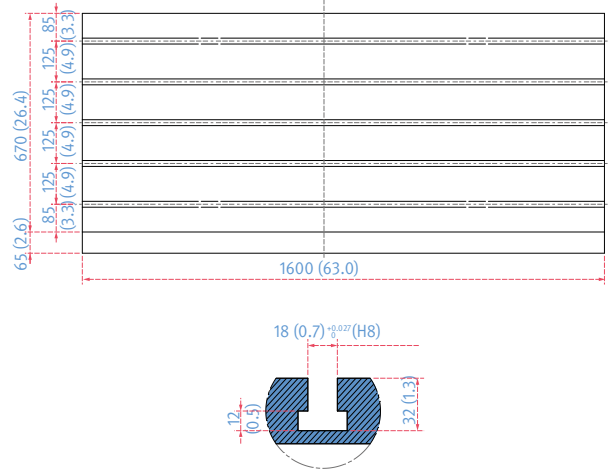

## DNM 6700XL

Units : mm (inch)

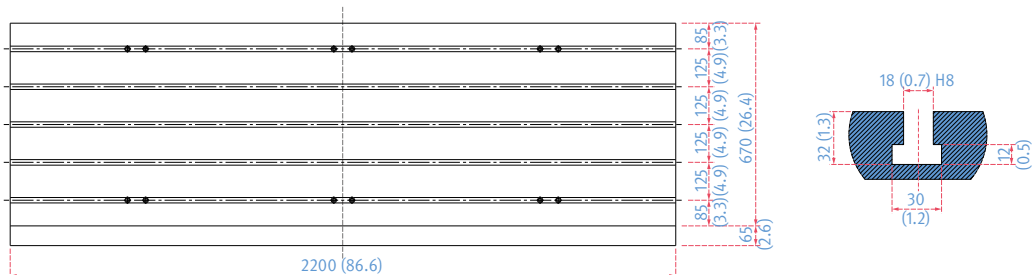

# MACHINE SPECIFICATIONS

Description			Unit	DNM 4500	DNM 4500L	DNM 5700	DNM 5700L	DNM 6700	DNM 6700L	DNM 6700XL	
Travels	Travel distance	X axis	mm (inch)	800 (31.5)	910 (35.8)	1050 (41.3)	1300 (51.2)	1300 (51.2)	1500 (59.1)	2100 (82.7)	
		Y axis	mm (inch)	450 (17.7)			570 (22.4)		670 (26.4)		
		Z axis	mm (inch)	510 (20.1)					625 (24.6)		
	Distance from spindle nose to table top	mm (inch)	150~660 (5.9~26.0)					150~775 (5.9~30.5)			
Table	Table size	mm (inch)	1000 x 450 (39.4 x 17.7)	1050 x 450 (41.3 x 17.7)	1300 x 570 (51.2 x 22.4)	1500 x 570 (59.1 x 22.4)	1500 x 670 (59.1 x 26.4)	1600 x 670 (63.0 x 26.4)	2200 x 670 (86.6 x 26.4)		
	Table loading capacity	kg (lb)	600 (1322.8)			1000 (2204.6)		1300 (2866.0)			
	Table surface type	mm (inch)	T-SLOT (3-125(4.9) x 18(0.7) H8)			T-SLOT (4-125(4.9) x 18(0.7) H8)		T-SLOT (5-125(4.9) x 18(0.7)H8)			
Spindle	Taper		-	ISO #40							
	Max. spindle speed	Fanuc	r/min	8000 {8000*, 12000, 15000}							
		Siemens	r/min	12000 {15000}							
		Heidenhain	r/min	12000 {15000}							
		Mitsubishi	r/min	12000 {15000}							
	Max. Spindle power	Fanuc	kW (Hp)	18.5/11 (24.8/14.8) {15/11 (20.1/14.8)*, 18.5/11 (24.8/14.8), 18.5/11 (24.8/14.8)}				18.5/15 (24.8/20.1) {15/11 (20.1/14.8)*, 18.5/11 (24.8/14.8), 18.5/11 (24.8/14.8)}			
		Siemens	kW (Hp)	16.5/11 (22.1/14.8) {16.5/11 (22.1/14.8)}				21.8/16.3 (29.2/21.9) {16.5/11 (22.1/14.8)}			
		Heidenhain	kW (Hp)	17/10 (22.8/13.4) {17/10 (22.8/13.4)}				32/15 (42.9/20.1) {17/10 (22.8/13.4)}			
		Mitsubishi	kW (Hp)	18.5/11 (24.8/14.8)							
	Max. spindle torque	Fanuc	N·m (lbf-ft)	117.8 (86.9) {286 (211.1)*, 117.8 (86.9), 117.8 (86.9)}							
Siemens		N·m (lbf-ft)	141.3 (104.3) {141.3 (104.3)}				150.1 (110.7) {141.3 (104.3)}				
Heidenhain		N·m (lbf-ft)	108.2 (79.9) {108.2 (79.9)}				203.7 (150.2) {108.2 (79.9)}				
Mitsubishi		N·m (lbf-ft)	117.8 (86.9)								
Feedrates	Rapid traverse rate	X axis	m/min (ipm)	36 (1417.3)						30 (1181.1)	
		Y axis	m/min (ipm)	36 (1417.3)						30 (1181.1)	
		Z axis	m/min (ipm)	30 (1181.1)							
Automatic Tool Changer	Type of tool shank	Tool shank	-	BT 40 {CAT 40 / DIN 40}							
		Pull stud	-	PS806 {Modified DIN / DIN 69872 #40}							
	Tool storage capa.	ea	30 {40, 60}								
	Max. tool diameter	Continous	mm (inch)	80 (3.1) {76 (3.0)}							
		Without Adjacent Tools	mm (inch)	125 (4.9)							
	Max. tool length	mm (inch)	300 (11.8)								
	Max. tool weight	kg (lb)	8 (17.6)								
	Max. tool moment	N·m (ft-lbs)	5.88 (4.3)								
	Tool selection		MEMORY RANDOM								
	Tool change time (Tool-to-tool)	sec	1.2								
Tool change time (Chip-to-chip)	sec	3.2					3.5				
Power source	Electric power supply (rated capacity)	kVA	29.5				38.1 {33.0**}		40 {35}*		
	Compressed air supply	MPa (psi)	0.54 (78.3)								
Tank capacity	Coolant tank capacity	L (gal)	260 (68.7)	285 (75.3)	310 (81.9)	350 (92.5)	325 (85.9)	430 (113.6)	440 (116.2)		
Machine Dimensions	Height	mm (inch)	2985 (117.5)					3120 (122.8)			
	Length	mm (inch)	2158 (85.0)			2413 (95.0)		2597 (102.2)		2970 (116.9)	
	Width	mm (inch)	2615 (103.0)	2701 (106.3)	3110 (122.4)	3350 (131.9)	3350 (131.9)	3650 (143.7)	4800 (189.0)		
	Weight	kg (lb)	5000 (11023.0)	5500 (12125.2)	6500 (14329.8)	7000 (15432.1)	8500 (18739.0)	9000 (19841.3)	10000 (22045.9)		
Control	NC system	-	DN Solutions Fanuc i Plus / SIEMENS S828D / HEIDENHAIN TNC620 / MITSUBISHI M80A								

\* { } : Optional \* 8000 r/min High torque version(FANUC only) \*\* Power capacity of 8000 r/min high torque and 12000 r/min spindle



The DN Solutions promise, MACHINE GREATNESS, has two important meanings. The first is simple: DN Solutions makes great machines. The second is a challenge to our end-users. With a product line that is this comprehensive, accurate and reliable, we equip our customers to machine greatness. The big question: **Why should you choose DN Solutions over other options?**

Here's why...



**MACHINE  
GREATNESS™**



WHAT YOU MAKE AND HOW YOU MAKE IT MATTERS—SO MAKE IT  
GREAT WITH DN SOLUTIONS.

## UNBEATABLE MACHINES

You won't find a more comprehensive range or a better combination of value, performance and reliability anywhere else.

---

## ROBUST PRODUCT LINE

We offer an impressive range of machine models and hundreds of configurations. Whatever your machining needs and requirements, there's a DN Solutions for you.

## READILY AVAILABLE - ANYWHERE IN THE WORLD

Machining centres (including 5-axis machines), lathes, multi-tasking turning centres and mill-turn machines, and horizontal borers with best-in-class specifications are all available...ready to install.

---

## EXPERT SERVICE

Our dedicated, experienced and knowledgeable team is totally committed to improving your productivity, growth and success.

# CUSTOMER SUPPORT AND SERVICES

**We're there for you whenever you need us.**

We help our customers operate at maximum efficiency by providing them with a range of tried, tested and trusted services - from pre-sales consultancy to post-sales support.

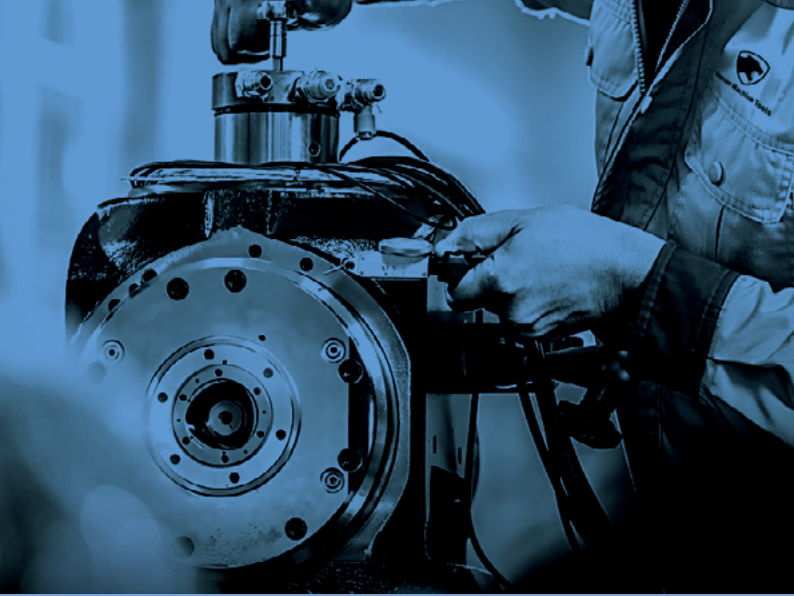

## FIELD SERVICES

- On-site service
- Machine installation and testing
- Scheduled preventive maintenance
- Machine repair service



## PARTS SUPPLY

- Supplying a wide range of original DN Solutions spare parts
- Parts repair service



## TRAINING

- Programming, machine setup and operation
- Electrical and mechanical maintenance
- Applications engineering



## TECHNICAL SUPPORT

- Supports machining methods and technology
- Responds to technical queries
- Provides technical consultancy



# RESPONDING TO CUSTOMERS ANYTIME, ANYWHERE

## DN Solutions Global Network

DN Solutions provides systems-based professional support services, before and after the machine tool sale, by responding quickly and efficiently to customers. By supplying spare parts, product training, field service and technical support, we provide the expert care, attention and assistance our customers expect from a market leader.



## Global sales and service support network

<b>4</b>	<b>Corporations</b>
<b>156</b>	<b>Dealer networks</b>
<b>51</b>	<b>Technical centers</b> Technical Center, Sales Support, Service Support, Parts Support
<b>200</b>	<b>Service posts</b>
<b>3</b>	<b>Factories</b>





[dn-solutions.com](http://dn-solutions.com)

**Head Office**

22F T Tower, 30, Sowol-ro 2-gil  
Jung-gu, Seoul, Korea, 04637

Tel: +82-2-6972-0370/0350  
Fax: +82-2-6972-0400

**DN Solutions America**

19A Chapin Road, Pine Brook  
New Jersey 07058, United States

Tel: +1-973-618-2500  
Fax: +1-973-618-2501

**DN Solutions Europe**

Emdener Strasse 24, D-41540  
Dormagen, Germany

Tel: +49-2133-5067-100  
Fax: +49-2133-5067-111

**DN Solutions India**

No.82, Jakkuar Village  
Yelahanka Hobli, Bangalore-560064

Tel: + 91-80-2205-6900  
E-mail: [india@dncompany.com](mailto:india@dncompany.com)

**DN Solutions China**

Room 101,201,301, Building 39 Xinzhuan  
Highway No.258 Songjiang District  
China Shanghai (201612)

Tel: +86 21-5445-1155  
Fax: +86 21-6405-1472

**Sales inquiry**

[sales@dncompany.com](mailto:sales@dncompany.com)

\* For more details, please contact DN Solutions.

\* Specifications and information contained within this catalogue may be changed without prior notice.